

2/10/96

1. PRODUCT

12 OZ. CANS - 2.60 x 4.84 Long

2. PRODUCT CAPACITY

48 PER COLUMN - 72", 57 PER COLUMN - 79"

3. SET UP GUIDE UNIVENDOR-2

Product	CAM POSITION	BACK SPACER	GAGE BAR	Sold out Lever	SIDE SPACER	GAGE BAR CLIP	
						Part No.	Position
12 oz CANS	3	8	2	389242 SHORT	1060686	1066104 White	1 & 2

Note: To properly vend 12 oz. Cans. The Univendor-2 must have the columns setup correctly.

4. GAGE BAR CLIP SET UP.

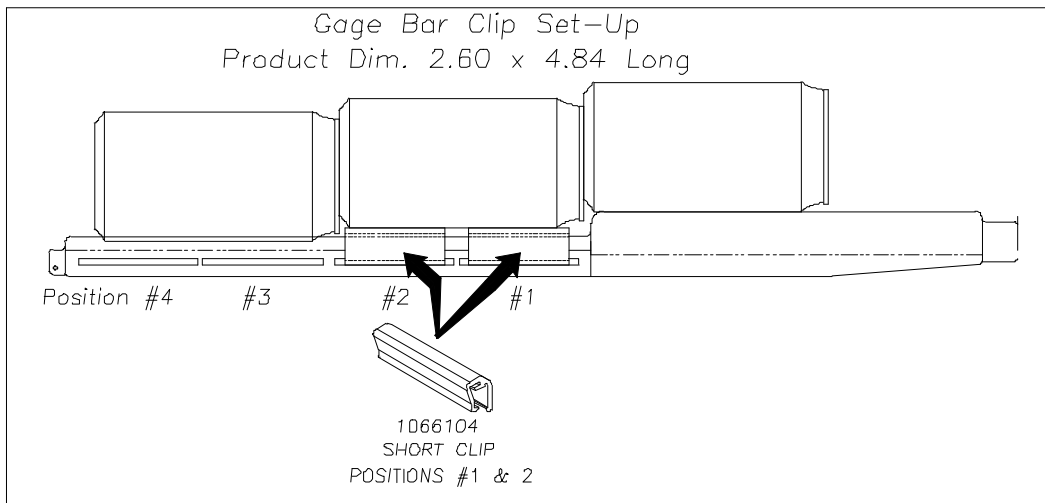

5. SET UP GUIDE.

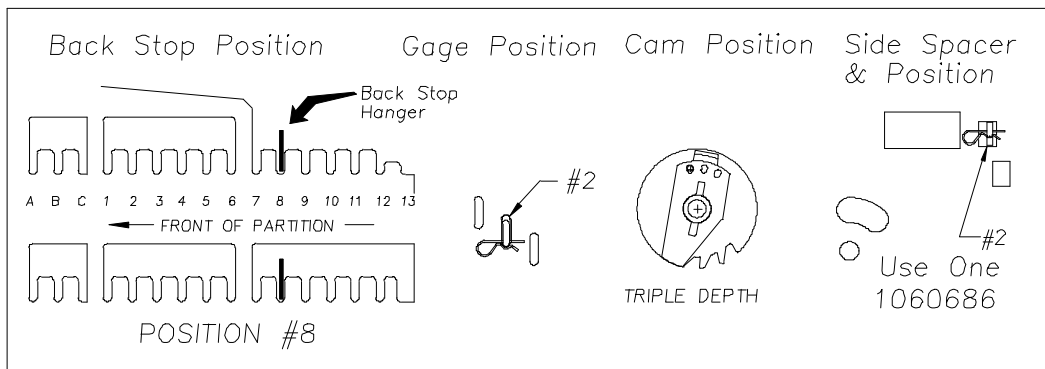

6. SOLD-OUT LEVER TO BE SHORT STYLE WITH FRONT SPACER. SPRING TO BE LOCATED ON THE RIGHT SIDE (LOW PRESSURE SETTING).