

**1. PRODUCT**

**15.5 OZ. ALL YOO-HOO GLASS BOTTLE - 2.91 Top x 2.95 Btm x 7.20 Long**

**2. PRODUCT CAPACITY**

**26 PER COLUMN - 72", 32 PER COLUMN - 79"**

**3. SET UP GUIDE UNIVENDOR-2**

Product	CAM POSITION	BACK SPACER	GAGE BAR	Sold out Lever	SIDE	TRIM	GAGE BAR CLIP	
					SHIM	KIT	Part No.	Position
15.5 oz YOO-HOO	2	9	1	389242 SHORT	NONE	1085848	1066112-1	1

**Note:** To properly vend 15.5oz. YOO-HOO. The Univendor-2 must have the columns setup correctly.

**4. GAGE BAR CLIP SET UP.**

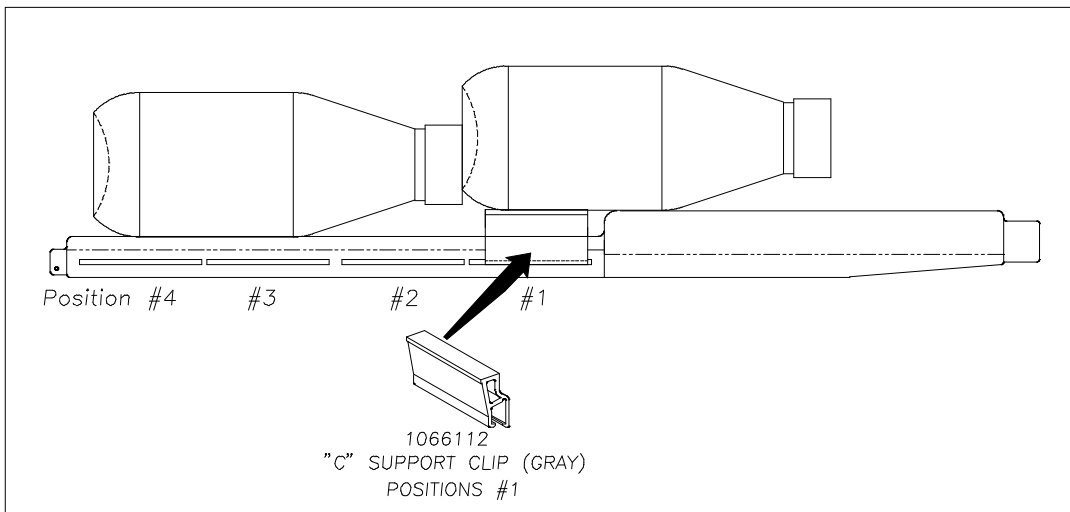

**5. SET UP GUIDE.**

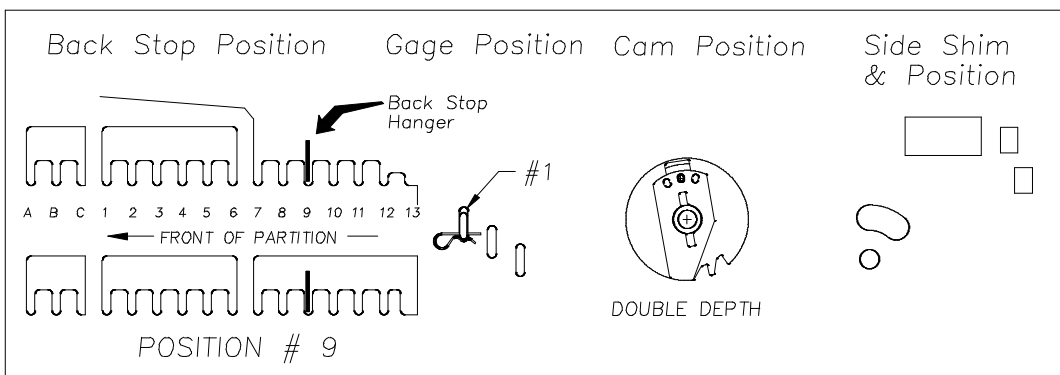

**6. SOLD-OUT LEVER TO BE SHORT STYLE WITH FRONT SPACER. SPRING TO BE LOCATED ON THE RIGHT SIDE (LOW PRESSURE SETTING).**

**7. FOR OTHER PRODUCT SET UP GUIDES CONTACT THE VENDO ENGINEERING COMPANY. TEL: (209) 439-1770 FAX: (209) 439-2083.**